

MINIATURE RESISTANCE TEMPERATURE DETECTOR

R

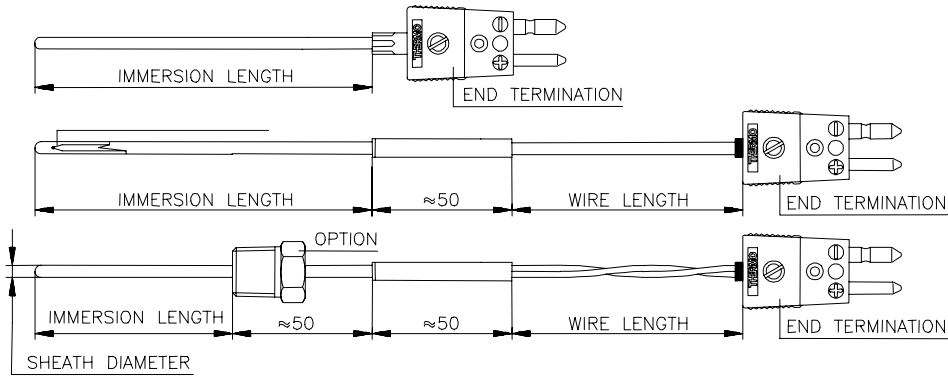

Construction:

1. Rigid	
2. Bendable	

Wire type:

2-wire		3-wire		4-wire	
--------	--	--------	--	--------	--

A	P/TW	: PVC insulated single	F	HF/D	: Kapton insulated
B	P/PTW	: PVC insulated	G	Si/SiTW	: Silicon insulated
C	P/CuPTW	: PVC insulated + copper braided	H	Flex. armour + TEX/TW:	Flex. armour over Teflon insulated
D	TEX/TW	: Teflon insulated	J	G/G	: Fibreglass insulated
E	TEX/CuTEXTW	: Teflon insulated + copper braided	K	G/GS	: Fibreglass ins. + SS overall braiding

End termination

A		K		V ⁵	
B		M			
D		L			
C		P / U			

⁵ For flexible armour only)

Options

A		C ⁶		E ⁷	
B		D			

⁶ Only for standard & miniature, ⁷ Only for Ø. 1,5 to 3,0 sheath dia.)

Because of the large number of possible combinations, some constructions will be subject to availability of materials and technical feasibility. Please contact your nearest THERMO ELECTRIC office for confirmation.