

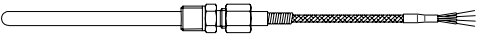

TEMPERATURE SENSORS

Marine applications and heavy environments

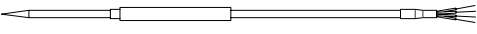

Specifications:

APPLICATION	SENSOR	DESCRIPTION AND CATALOG SHEET no.
STORAGE		
Coolers, containers. Temperature Range -30 °C to +70 °C.		Resistance thermometer for direct immersion. Datasheet D/340.
Cargo and inside storage rooms. Temperature Range -30 °C to +60 °C.		Resistance thermometer for mounting on storage. Datasheet D/340.
Cargo temperature. Temperature Range -30 °C to +60 °C.		Resistance thermometer for penetration in cargo. Datasheet D/340.

AIR

Ambient air in storage rooms.
Temperature Range -30 °C to +70 °C.

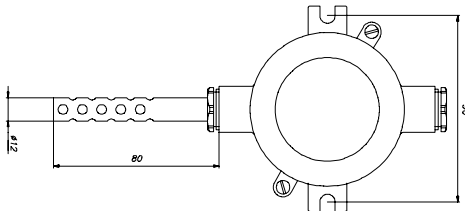

Wall mounting resistance thermometer.
Datasheet D/350.

Cooling vent pipes and storage rooms.
Temperature Range -30 °C to +70 °C.

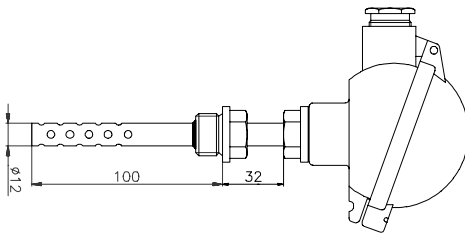

Direct immersion resistance thermometer with connection head.
Datasheet D/350.

Cooling vent pipes and storage rooms.
Temperature Range -30 °C to +70 °C.

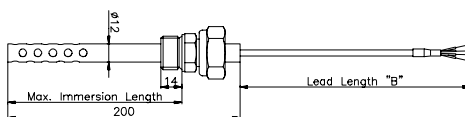

Direct immersion resistance thermometer with extension leads.
Datasheet D/350.



Thermo Electric
P.O. Box 179
2740 AD Waddinxveen
The Netherlands

Tel. : +31 (0)182 – 302 850
Fax : +31 (0)182 – 302 777
E-mail : info@thermo-electric.nl
Internet: <http://www.thermo-electric.nl>

D/301